

Vélo semi-allongé

Le vélo
DP649

**Mobilisation articulaire et musculaire
membres inférieurs.**

Fonctions mises en œuvre :

Favorise la flexibilité et la mobilité des articulations supérieures et inférieures. Améliore et augmente la capacité cardio-pulmonaire.

Selon la norme EN 16630: N'exige pas un sol qui amortit les impacts selon le test HIC de la norme EN-1176.

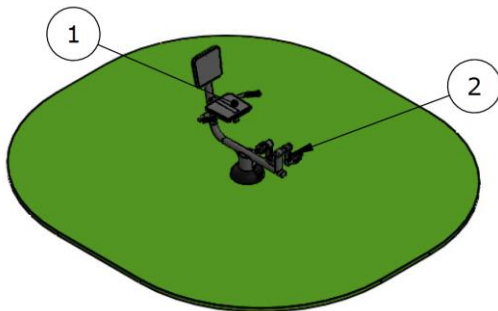

1. Siège
2. Pédales

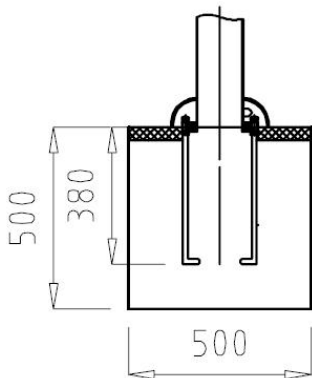
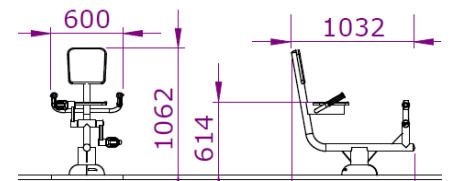
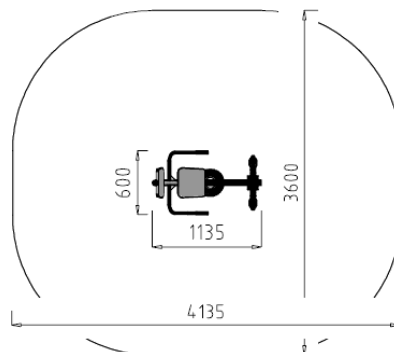

EN 16630

- h > 1,4 m, < 150 kg
- 0,57 m
- 35 Kg
- 1,13 x 0,60 x 0,98 m
- 3,6 x 4,13 m
- 12,95 m²

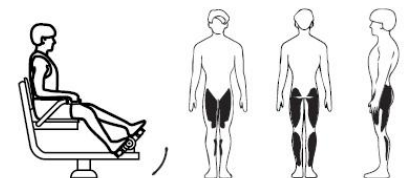

UrbaGym

DP649

VELO SEMI-ALLONGE

